

**260  
Floor Scrubber  
Traction Driven  
Brush Driven**

**Model:  
MC260024QP  
MC260026QP  
MC260024CE  
MC260026CE**

**OPERATION**

**SERVICE**

**PARTS**

**CARE**

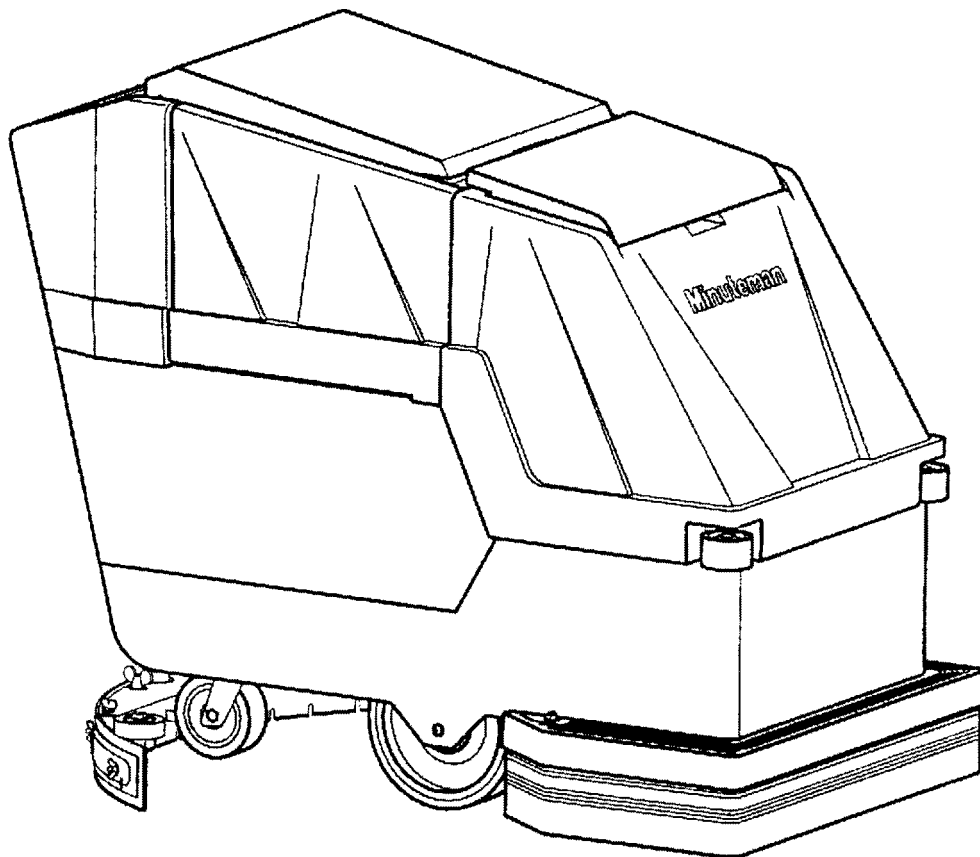

Revised 8/03

***Minuteman***<sup>®</sup>

# EC Declaration of Conformity

according to Directives 89/392, 89/336, 72/73

We, Minuteman International Incorporated, of 111 South Rohlwing Road Addison Illinois 60101 USA, declare under our sole responsibility that the products MC260024CE, MC260026CE, MC260027CE, MC265024, MC265026 Commercial Automatic Floor Scrubbing machines to which this declaration relates corresponds to the relevant requirements of the EC Directives 89/392, 89/336 and 72/73. The following standards were used to determine compliance with the Directives: EN 292, EN 294, EN 811, EN 55011, EN 55104, EN 50082-2, EN 60335-1 and IEC 335-2-72.

<b>SOUND</b>		<b>VIBRATION</b>						
<b>77 dB Operator</b>	<b>74 dB At 3m</b>	<b>1 m/s<sup>2</sup> At Operators Hand Grips</b>						
<p>Tests were conducted on 6/7/96 with calibrated sound and vibration equipment under the conditions noted below:</p> <table style="width: 100%; border: none;"> <tr> <td style="width: 50%;">General Condition: Cloudy</td> <td style="width: 50%;">Wind: 0 km/hr</td> </tr> <tr> <td>Temperature: 29<sup>o</sup>C</td> <td>Humidity: 85%</td> </tr> <tr> <td>Barometric Pressure: 29.5</td> <td></td> </tr> </table>			General Condition: Cloudy	Wind: 0 km/hr	Temperature: 29 <sup>o</sup> C	Humidity: 85%	Barometric Pressure: 29.5	
General Condition: Cloudy	Wind: 0 km/hr							
Temperature: 29 <sup>o</sup> C	Humidity: 85%							
Barometric Pressure: 29.5								

  
 \_\_\_\_\_  
 Jeff Pollack, Standards Engineer

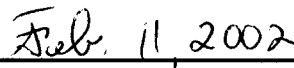
  
 \_\_\_\_\_  
 Date

## TABLE OF CONTENTS

	<b>Page</b>
Safety Instructions	1
Electrical Requirements	2
Control Panel Identification	3
Squeegee Adjustments	4
Operating Instructions	5
Main Polyethylene Components	6 & 7
Recovery Tank and Solution Tank	8 & 9
Drive Assemblies (Brush Driven)	10 & 11
Mainframe (Brush Driven)	12 & 13
Console Assembly (Brush Driven)	14 & 15
Recovery Tank and Solution Tank	16 & 17
Drive Assemblies (Traction Driven)	18 & 19
Mainframe (Traction Drive)	20 & 21
Console Assembly (Traction Driven)	22 & 23
Squeegee Mechanism Assembly	24
Squeegee Assembly Complete	25
Wiring Diagram (Brush Driven)	26
Wiring Diagram (Brush Driven, CE Model)	27
Wiring Diagram (Traction Driven)	28
Wiring Diagram (Traction Driven, CE Model)	29

# IMPORTANT SAFETY INSTRUCTIONS

## CAUTION

Operators must read and understand this manual before operating or maintaining this equipment.

- Keep hands and feet clear of moving parts while machine is in operation.
- All switches must be in the “OFF” position when charging batteries.
- Electrical motors and components can cause an explosion when operated near explosive materials or vapors. Do not operate this machine near flammable materials such as solvents, thinners, fuels, grain dusts, etc.
- Make sure all switches are turned “OFF” and battery connections are removed before performing any maintenance procedures.
- Store or park this machine on a level surface only.
- These machines are designed for level floor operation only. DO NOT OPERATE on ramps or inclines.
- Battery acid can cause burns. When working on or around batteries, wear protective clothing and safety glasses. Remove metal jewelry. Do not lay tools or metal objects on top of batteries.
- This machine is not suitable for picking up hazardous dust.
- Charging batteries generates explosive gases. DO NOT CHARGE BATTERIES WHEN OPEN FLAMES OR SPARKS ARE PRESENT. DO NOT SMOKE. Make sure the charger is turned off before disconnecting it from the batteries. Charge the batteries in a well-ventilated area.
- Maintenance and repairs must be performed by authorized personnel.

**SAVE THESE INSTRUCTIONS**

## ELECTRICAL REQUIREMENTS:

This piece of equipment operates on 24 Volt DC.

## BATTERY REQUIREMENTS:

4 x 6V 220AH P/N 956720

4 x 6V 275AH P/N 956740

## BATTERY SERVICE AND INSTALLATION:

\* Warning: Battery acid can cause burns. When working on or around batteries, wear protective clothing and safety glasses. Remove metal jewelry. Do not lay tools or metal objects on top of batteries.

## BATTERY INSTALLATION:

1. Disconnect tank drain hose from rear of machine (6).
2. Raise tank assembly by raising rear cover and tilting tank, Figure 1.
3. Install batteries as shown in Figure 2.

## CHARGING OF BATTERIES:

Charging of batteries generates explosive gases. DO NOT CHARGE BATTERIES WHEN OPEN FLAMES OR SPARKS ARE PRESENT. DO NOT SMOKE. Make sure the charger is turned off before disconnecting it from the batteries. Charge the batteries in a well-ventilated area. Fluid levels should be checked before and after charging and maintained at the proper levels.

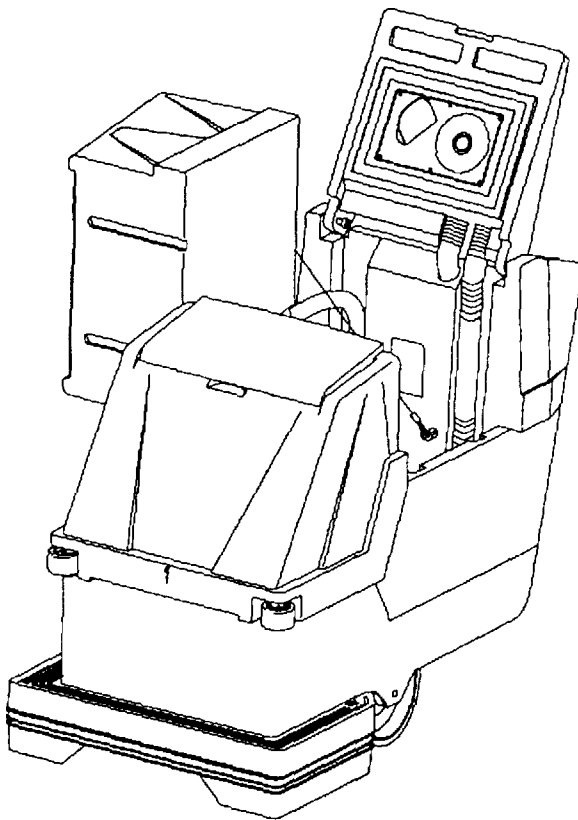

Figure 1

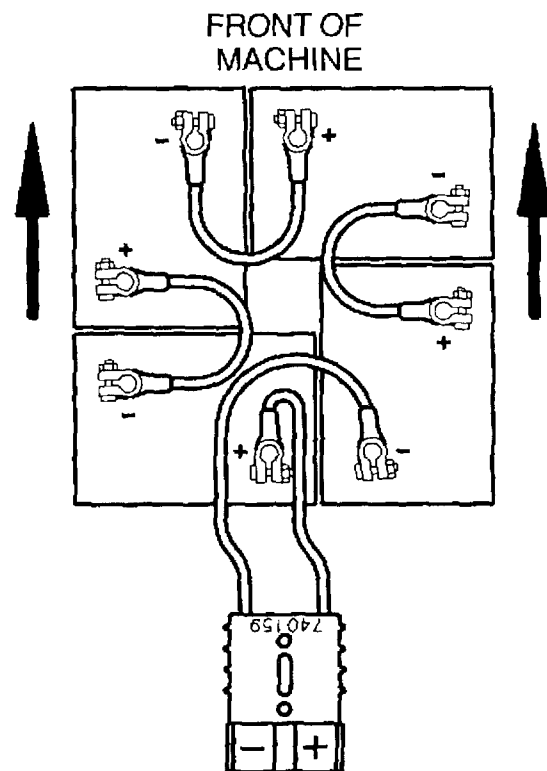
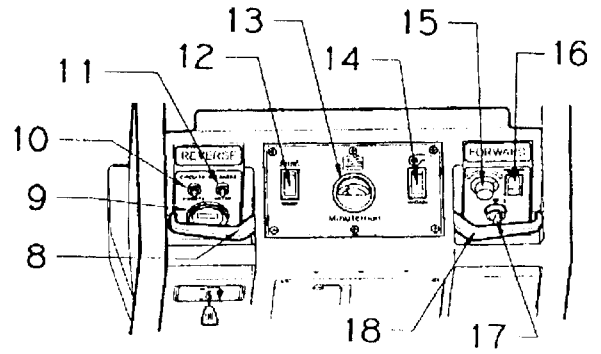
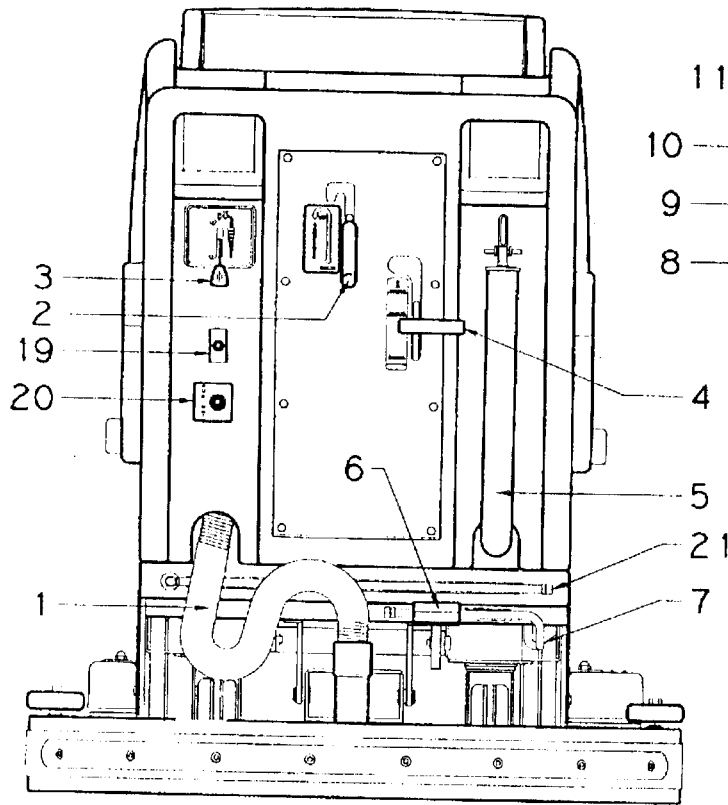

Figure 2

# CONTROL PANEL IDENTIFICATION



1. Vacuum recovery hose
2. Squeegee lift lever
3. Solution control lever
4. Brush pressure handle
5. Drain hose for recovery tank
6. Foot pedal for lower/raising brush
7. Drain hose for battery tray
8. Reverse control lever
9. Hour meter (optional)
10. Circuit breaker for vacuum motor
11. Circuit breaker for brush motor
12. Brush switch
13. Battery condition gauge
14. Vacuum switch
15. Speed control knob
16. Main power switch
17. Key switch (optional)
18. Forward control lever
19. Pump switch (optional)
20. Quick disconnect aux. out (optional)
21. Dump hose for solution tank

## AUTO SCRUBBER BRUSH DESCRIPTION

TYPE	DESCRIPTION	DURABILITY*	COLOR	COMPARISON TO PADS	RECOMMENDED USE
Bassine	Natural Fiber	Short	Dark Brown	Red	Light duty general cleaning, acid etching
Nylon	Nylon	Medium	Black	Tan/Red	General cleaning & scrubbing vinyl floors, ceramic tile & concrete floors
Dyna-Scrub	Nylon impregnated with 500 Grit Silicone Carbide Fine Bristle, Dense Fill	Long	Light Blue	Red	General scrubbing, vinyl tile, ceramic tile, epoxy floors, urethane finish, uneven concrete floors
Power-Scrub	Nylon impregnated with 120 Grit Silicon Carbide Fine Bristle, Dense Fill	Long	Rust	Red/Blue	Moderate aggressive scrubbing, tile floors concrete floors
Poly-Grit	Nylon impregnated with 80 Grit Silicon Carbide Coarse Bristle	Long	Green	Brown/Black	Aggressive stripping and scrubbing, tile floors, unfinished concrete floors
Strata-Grit	Nylon impregnated with 46 Grit Silicon Carbide Coarse Bristle	Long	Dark Blue	Black	Heavy duty stripping/scrubbing unfinished concrete

\* Durability is dependent on floor surface, chemicals used and proper care.

## SQUEEGEE ADJUSTMENTS

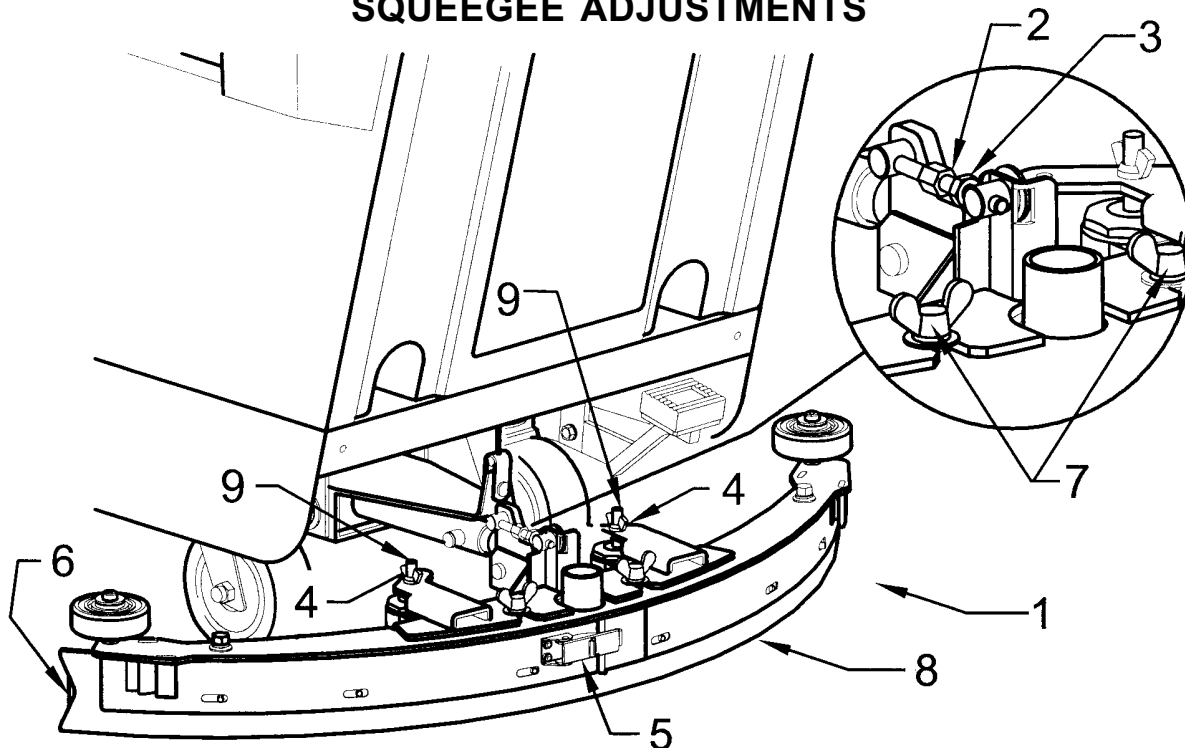

**The squeegee set-up is pre-adjusted at the factory. Adjustments may be required to get optimum performance for different floors and conditions.**

1. Ensure that the scrubber is on a relatively flat surface. Turn on the main power switch and raise the scrubhead assembly off the floor. Lower the squeegee to the floor.
2. Turn the speed control knob counter-clockwise to the low speed position. Squeeze the forward control lever to lower the squeegee (item 1) to the floor. Move the machine one or two feet forward to check the rear squeegee blade (item 8) for uniform deflection to the floor.
3. If uneven deflection or lay is evident, minor adjustments may be necessary to avoid streaking and uneven wear on the blade.
4. To correct this, loosen the wing jam nut (item 4) in order to adjust the caster height. If the squeegee blade is deflecting too much, the casters need to be lowered to control the down pressure. Lower the caster by turning the exposed threaded stem (item 9) on the caster clockwise. Make the adjustment a few turns at a time.
5. Repeat step 2.
6. If the blades are not deflecting enough, raise the caster by turning the stem counter-clockwise to adjust the caster height to allow more down pressure on the squeegee. Repeat step 2.
7. Make sure that there is even deflection on the entire length of the rear blade. Adjust the casters and retighten the wing jam nuts to lock the caster setting in place.
8. Pitch adjustment is necessary if the outer ends on the squeegee blade does not contact the floor and there is too much deflection in the middle area or if the outer ends are over deflected and there is no contact in the middle.
9. To adjust the pitch, lower the squeegee to the floor. Loosen the lock nut (item 3) in the turnbuckle assembly. Turning the turnbuckle (item 2) clockwise or counter-clockwise controls the forward and backward pitch of the squeegee. Having the rear blades deflected uniformly along its entire length is the desired set-up.
10. Repeat step 2 until the desired set-up is achieved.
11. In certain applications where a non-slotted front wiper blade (item 6) is needed, detach the squeegee assembly by loosening the wing bolts (item 7). Unlock the clamp on the front squeegee to release the straps and flip the blade over to the non-slotted side. Reattach straps and lock the clamp back in place.
12. You can also easily replace the rear blade by unlatching the latch (item 5) and removing the straps by sliding them off the assembly.

## OPERATING INSTRUCTIONS

1. Filling: Fill the solution tank with the desired amount of water and add liquid cleaning solution to the proper dilution ratio. DO NOT USE powdered cleaning chemicals. Powders are unlikely to dissolve thoroughly, resulting in clogging the in-line solution filter. This can reduce or stop water flow to the brush.
2. Close lid.
3. Turn on main power switch (refer to Page 3, #16). (Traction Drive Only)
4. Adjust main speed control, #15 to full counter-clockwise position. (Traction Drive Only)
5. Lower brush assembly:
  - Depress foot pedal (7) slightly and push in on lever (5) to release, to increase brush pressure pull up and back on lever (5) to lock in position.
  - To lift the brush, press the pedal down until lift mechanism engages.
6. Turn on brush switch.
7. Adjust solution control feed lever.
8. Select vacuum operation:  
Brush Driven Models – Turn vacuum switch to “On” position Traction Driven Models
  - a) “Vacuum On” mode – Vacuum will remain on until switched to the “off” position
  - b) “Vacuum Auto” mode – Vacuum will come on automatically when forward or reverse handles are squeezed, and remain on approximately 5 seconds after handle release.
9. Lower squeegee assembly.
10. Squeeze forward handle #18 and adjust forward speed. (Traction Drive Only)

### After Use:

1. Turn off solution feed.
2. Switch off brush and raise.
3. Raise squeegee assembly.
4. Turn off vacuum motor.
5. Solution and recovery tanks should be emptied after every use.

## MAINTENANCE:

### Daily

1. Clean float assembly & squeegee blades.
2. Recharge batteries (check battery acid levels before and after charging).

### Monthly

1. Check wear on squeegee blades.
2. Grease front and rear wheels.
3. Grease pivot points on brush motor assembly.

Every 500 hours check condition of carbon brushes on vacuum motor and brush drive motor.



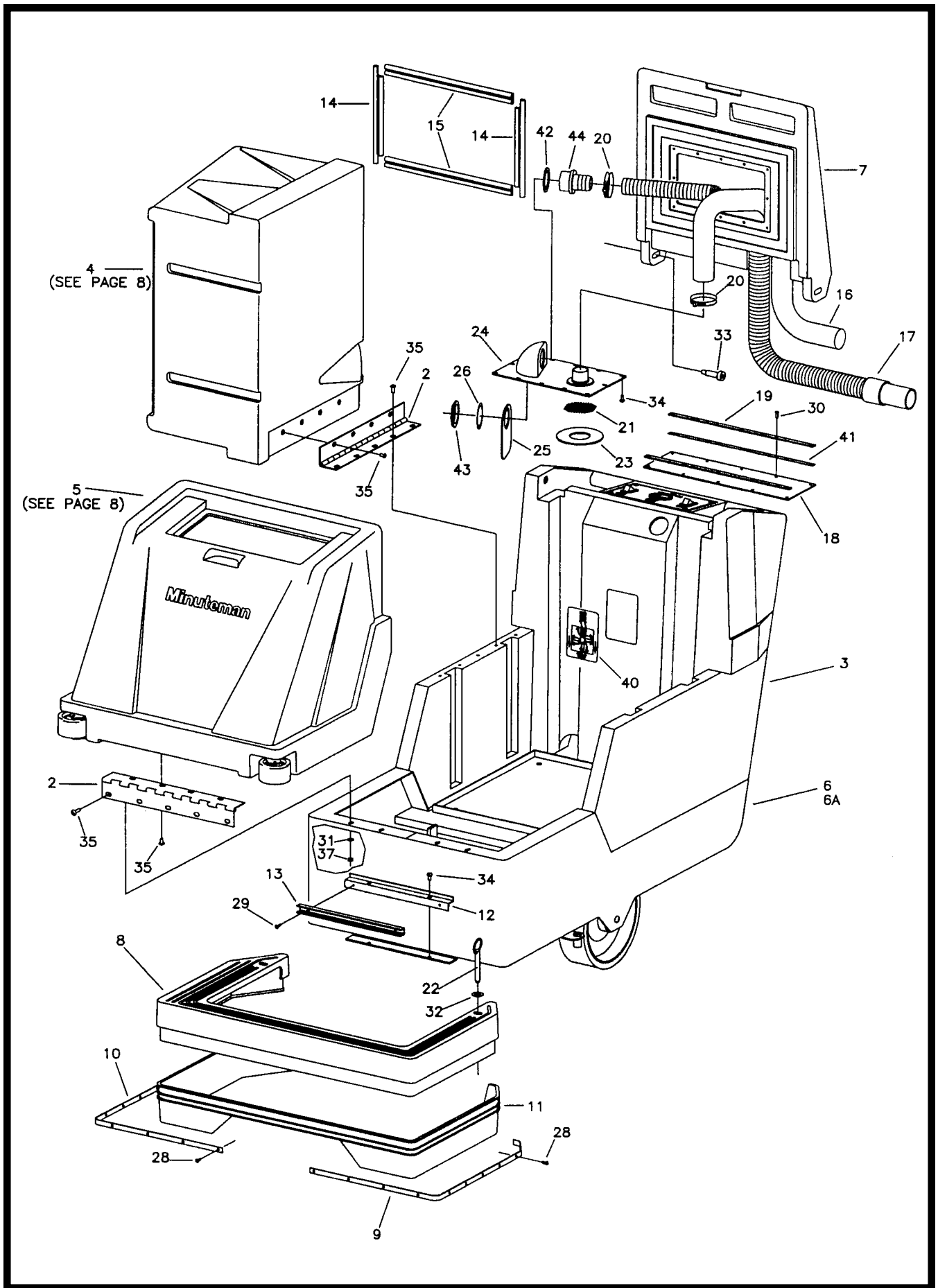

# Parts List

Item	Part No.	Qty.	Description
1			
2	260087	2	Hinge 15"
3	260090	1	Rear Base
4	260091	1	Recovery Tank
5	260092	1	Solution Tank
6	260093	1	Mainframe Weldment - BD
6A	260375	1	Mainframe Weldment - TD
7	260096B	1	Recovery Lid
8	260098	1	Front Skirt
9	260142	1	Skirt Retainer L.H.
10	260143	1	Skirt Retainer R.H.
11	260145	1	Splash Skirt
12	260148	1	Solution Dump Bracket
13	260149	1	U Channel 12"
14	260157	2	Lid Gasket Short
15	260158	2	Lid Gasket Long
16	260159	1	Vac Hose - White
17	260160	1	Recovery Hose Assy.
18	260169	1	Lid Flap
19	260170	2	Retainer Strip
20	260203	2	Hose Clamp, Wire Grip
21	260212	1	Screen Filter
22	260241	2	Hitch Pin 7/16 x 3"
23	260294	1	Gasket
24	260299	1	Shut-Off Plate Assy.
25	260301	1	Deflector Flap
26	450081	1	WSR-1.904 x 2.41 x .03 SS
27			
28	711106	20	SCR-ST-A 10 x .75 PL
29	711124	2	SCR-ST-B 10 x .37
30	711161	10	SCR-Hi/Lo 10 x 5/8
31	711505	4	WSR-Flat ¼
32	711508	2	WSR-Flat 7/16
33	712102	2	Bolt - Shoulder ½ x 1.50
34	712540	14	SCR-MC 10-24 x .37 SS TH
35	712565	17	SCR-MC ¼-20 x .62 SS
36			
37	712667	4	Nut-Nyloc ¼-20
38			
39			
40	715607	1	Decal - Battery Routing
41	760263	2	Foam Tape 16.50"
42	828970	1	WSR-Neop 1.87 x 2.4 x .125
43	828971	1	Nut - 1 ½ Pipe Thread
44	450037	1	Adapter MCH



# Parts List

Item	Part No.	Qty.	Description	Item	Part No.	Qty.	Description
1	260092	1	Solution Tank	26	711124	1	SCR-ST-B 10 x .37
2	260029	1	Solution Lid	27	450040	2	90° 3/8 Barb x 3/8 MPT
3	260091	1	Recovery Tank	28	260178	3	3/8 Barb Tee
4	450021	1	Hinge	29	260182	2	Hose Wire Reinforced 18"
5	712822	7	SCR-MC 10-24 x .37 SS TH	30	712041	2	Bolt-Shoulder 5/16 x .37
6	712764	7	WSR-Flat 10 SS	31	711506	2	WSR-Flat 5/16
7	832949	2	Bracket, Bumper	32	260179	4	Hose Nylobraid .5"
8	832896	2	Guide Wheel	33	833316	1	Drain Plug 1 1/4
9	833254	2	Bumper Wheel/Axle	34	260202	1	Drain Hose Assembly
10	710985	2	SCR-SC 3/8-16 x .62	35	260203	1	Hose Clamp Wire Grip
11	710353	2	SCR-MC 10-32 x .37	36	760220MCH	1	1.5 Adapter Gray
12	711553	2	WSR-Internal Lock 10	37	450081	1	WSR-SS 1.908 x 2.41 x .03
13	130118	1	Solution Strainer M3-40	38	828970	2	WSR-Neop 1.81 x 2.37
14	210409	1	Adapter Brass 3/8 FPT x 3/8 MPT	39	828971	1	Nut 1 1/2 Pipe Thread
15	711513	1	WSR-Flat .69 x 1.06 x .03 SS	40	260156	1	Foam Float Assembly
16	210414	1	O-Ring	41	712563	6	SCR-MCH 1/4-20 x 1.00 F.H.
17	210410	1	3/8 Hose Barb x 3/8 FPT Brass	42	260184	1	Backing Angle
18	830062	1	90° Street Elbow 3/8 x 3/8	43	712667	6	Nut-SS Nyloc 1/4-20
19	260214	2	Tank Cable Assy.	44	450076	13	Crimp Clamp SS 185R
20	260162	1	Hose, Clear 3/8 ID	45	828490	1	Hose Clamp
20A	260193	1	Hose, Nylobraid C/L 14.50	46	342430	1	Hose Barb 3/8 MPT x 3/8 Barb
21	828952	1	PLS 3/8 Barb x 1/4 MPT	47	210408	1	3/8 Brass Tee
22	430114	1	Nylon Cap 1/4 FPT	48	828975	1	WSR-Neoprene .75 x 1.5 x .09
23	210370	1	Solution Valve Cable Mount	49	711512	1	WSR-Flat .75 x 1.37 x .08
24	809413MCH	1	Valve Solution	50	829463	1	WSR-Flat D .75 x 2.00 x .05
25	210045	1	Solution Control Cable	51	450055	1	Hose Nylon Reinforced 9"
				52	260303	1	Deflector



# Parts List

## Brush Driven

Item	Part No.	Qty.	Description
1	260093	1	Mainframe Assy.
2	260090	1	Base Assy.
3	260055	1	Lift Handle Weldment
4	260046	1	Pedal Brace
5	260054	1	Pedal Weldment
6	210142	1	Pedal Pad
7	809247	2	Spacer .38 x .50 x .32
8	712081	2	Shoulder Bolt 3/8 x .75
9	260317	1	Squeegee Mechanical Assy. Complete
10	827110	2	Caster 5"
11	260044	1	Lift Arm, Right Side
12	260043	1	Lift Arm, Left Side
13	260128	1	Spacer
14	260125	1	Bushing, Yoke
15	260075	1	Yoke Weldment
16	711380	2	Nut, Nyloc 3/8-16
17			
18			
19	711375	2	Nut-Nyloc 3/8-16 Low
20	711546	12	Washer Helical 3/8
21	711250	2	Bolt HH 3/8-16 x 1.25
22	711439	3	Nut Flanged Wizz 3/8-16
23	713048	1	Bolt HH 3/8-16 x 2.50 #5
24	711507	2	WSR-Flat .37 x 1.12 x .06
25	260136	2	Axle Bracket Weldment
26	260130	2	Wheel 10"
27	762107	2	Spacer 1.00 x 1.25 x .25
28	260041	2	Oilite Flange Bushing
29	710992	1	Shoulder Bolt 1/2 x 1.25
30	711579	2	WSR-Flat 1/2 x 1.00
31	711242	8	Bolt HH 3/8-16 x 1.00
32	713045	1	Bolt HH 3/8-16 x 1.75 #5
33	260141	1	Spacer
34	762340	2	Oilite Bushing
35	712099	2	Shoulder Bolt 1/2 x .50
36	711228	8	Bolt HH 5/16-18 x .75
37	711545	16	Washer Helical 5/16
38	711575	22	Washer Flat 5/16
39	711232	4	Bolt HH 5/16-18 x 1.50
40	711374	2	Nut-Nyloc 5/16-18
41	711512	8	Washer Flat .75 x 1.38
42	710986	2	SCR BHCS 3/8-16 x 1.00
43	260030	5	1/2 Oilite Bushing
44	832829	2	Nut-Tinnerman 5/16-18
45	710196	4	SCR-MC 5/16-18 x .75
46	711515	8	WSR-Flat .44 x .87 x .07
47	712310	6	WSR-Flat .52 x .87 x .06
48	712680	4	Nut-Hex 5/16 -18 SS

# Brush Driven

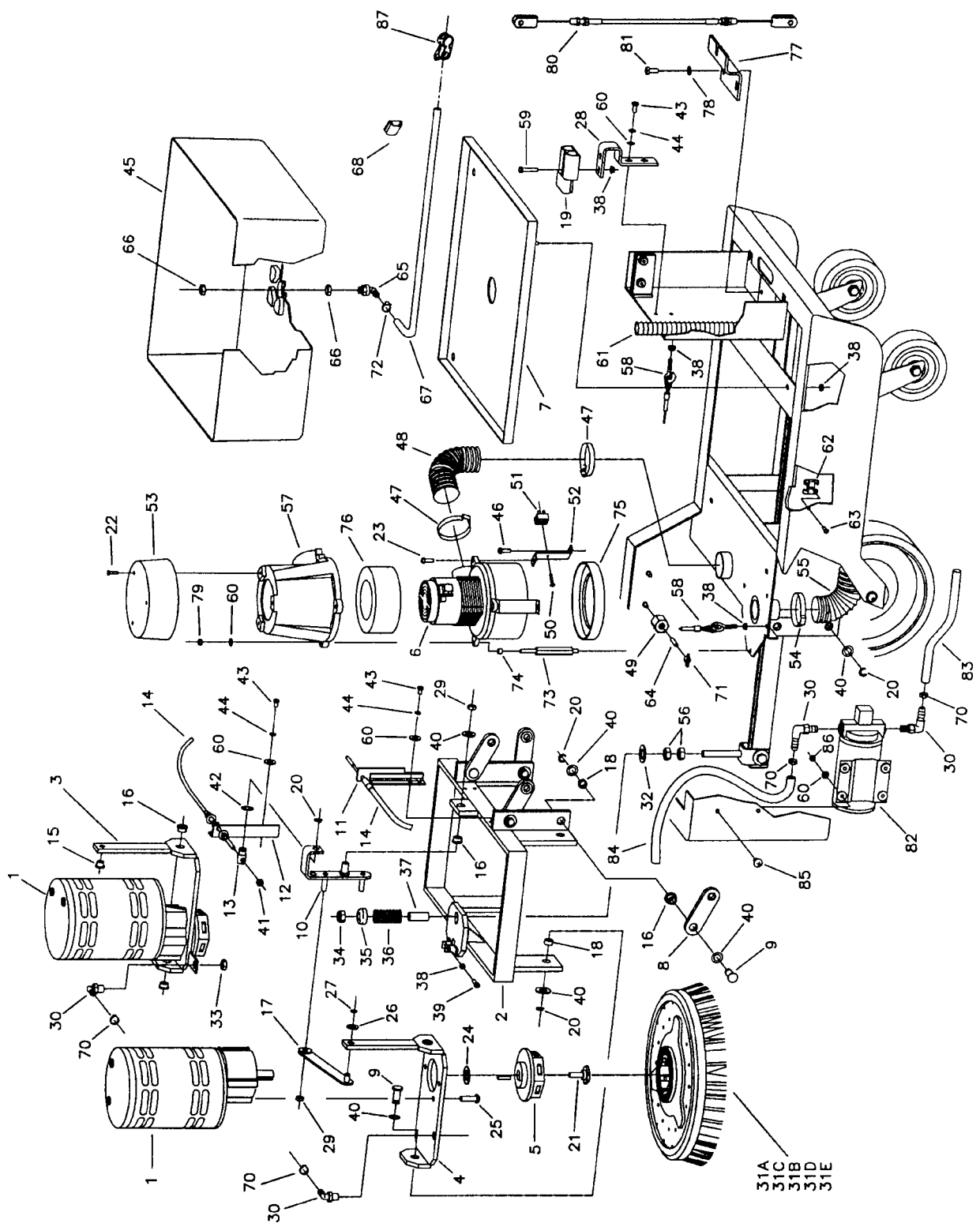

# Brush Driven Parts List

Item	Part No.	Qty.	Description	Item	Part No.	Qty.	Description
1	740209	2	Gearmotor 24V	42	711524	2	WSR-Wave .52 x .87 x .01
2	260077	1	Motor Frame	43	711203	6	Bolt-HH 1/4-20 x .62
3	260038	1	Motor Mount, R.H.	44	711535	6	WSR-Helical 1/4
4	260039	1	Motor Mount, L.H.	45	260150	1	Battery Liner
5	430035	2	Drive Hub	46	710180	2	SCR-MC 1/4-20 x .75
6	740225	1	Vac Motor 24V 3-Stage	47	829067	2	Hose Clamp
7	260009	1	Battery Tray	48	833191	1	Hose Rubber Flex 2 x 9
8	260049	4	Linkage Bar	49	740132	2	Insulator
9	260036	12	Pin	50	711128	1	SCR-TF 8 x .62
10	260042	1	Actuator Bar	51	832996	1	Terminal Block
11	260123	1	Cable Bracket, L.H.	52	450038-H	2	Z-Bracket VDE
12	260124	1	Cable Bracket, R.H.	53	840011	1	Vac Motor Cover, Top
13	762256PLT	2	Swivel Pin	54	260203	1	Wire Grip Hose Clamp
14	260053	2	Cable	55	260159	1	Vac Hose Clear 1.5 x .84
15	260066	2	3/8 Oilite Flange Bushing	56	711334	2	Nut-Hex 1/2-13
16	260041	13	1/2 Oilite Flange Bushing	57	840012	1	Vac Motor Cover, Bottom
17	260114	2	Linkage Arm	58	260214	2	Tank Cable Assembly
18	260030	8	1/2 Oilite Bushing	59	711210	2	Bolt-HH 1/4-20 x 1.25
19	740159	1	SB175 Red Quick Disconnect	60	711505	11	WSR-Flat 1/4
20	711713	14	1/2 Retaining Ring	61	260175	1	Conduit
21	210066	2	Drive Hub Retainer Bolt	62	833725	2	Cord Clip
22	711160	3	SCR-HI/LO 10 x .62	63	711161	2	SCR-HI/LO 10 x 5/8
23	712129	2	SCR-MC 1/4-20 x 1.00 HWH	64	833638	2	Brass Stud
24	711517	2	WSR-Flat .77 x 1.37 x .03	65	320271	1	Nozzle Body 90°
25	710986	8	SCR-SC 3/8-16 x 1.00	66	320272	2	Nozzle Body Lock Nut
26	712301	2	WSR-Flat .37 x .87 x .06	67	260224	1	Hose Clear 18"
27	711717	2	3/8 Retaining Ring	68	809444	1	Clip Cord
28	260076	1	Bracket Anderson Plug	69	450076	4	Crimp Clamp SS 185R
29	711375	3	Nut-Nyloc 3/8-16	70	711368	2	Wing Nut
30	833325	4	90° 3/8 Barb x 1/4 MPT	71	828490	1	Hose Clamp
31A	260002	2	Pad Driver	72	833265PLT	1	Stand-Off 1/4-20
31B	260003	2	Bassine Brush	73	762073	1	Spacer
31C	260004	2	Nylon Brush	74	290017	1	Molded Gasket
31D	260005	2	Poly-Grit Brush	75	380064	1	Foam Ring
31E	260006	2	Sirata-Grit Brush	76	260315	1	Lift Cable Bracket
32	711510	1	WSR-Flat .50 x 1.37 x .10	77	711545	2	WSR-Helical 5/16
33	260183	1	Nut-PLS 1/4 NPT	78	712667	1	Nut-Nyloc 1/4-20
34	364-816	1	Nut-Nyloc 1/2-13	79	260266	1	Squeeze Lift Cable Assembly
35	828264	1	Washer Cup	80	711228	1	Bolt-HH 5/16-18 x .75
36	260137	1	Compression Spring	81	833299	2	Pump 100 PSI 24V DC
37	260068	1	Sleeve, Spring	82	260194	1	Hose Nylonbraid C/L 50
38	711425	9	Nut-Flanged Wizz 1/4-20	83	260193	1	Hose Nylonbraid C/L 14.50
39	710823	2	SCR-SC 1/4-20 x .50 Nylon	84	712545	4	SCR-MC 10-32 x .87 SS
40	712310	25	WSR-Flat .52 x .87 x .06	85	711350	4	Nut-Hex Nyloc 10-32
41	711316	2	Nut-Hex 1/4-20	86	320273	4	Hose Shut-Off Clamp
				87		1	



# Brush Driven

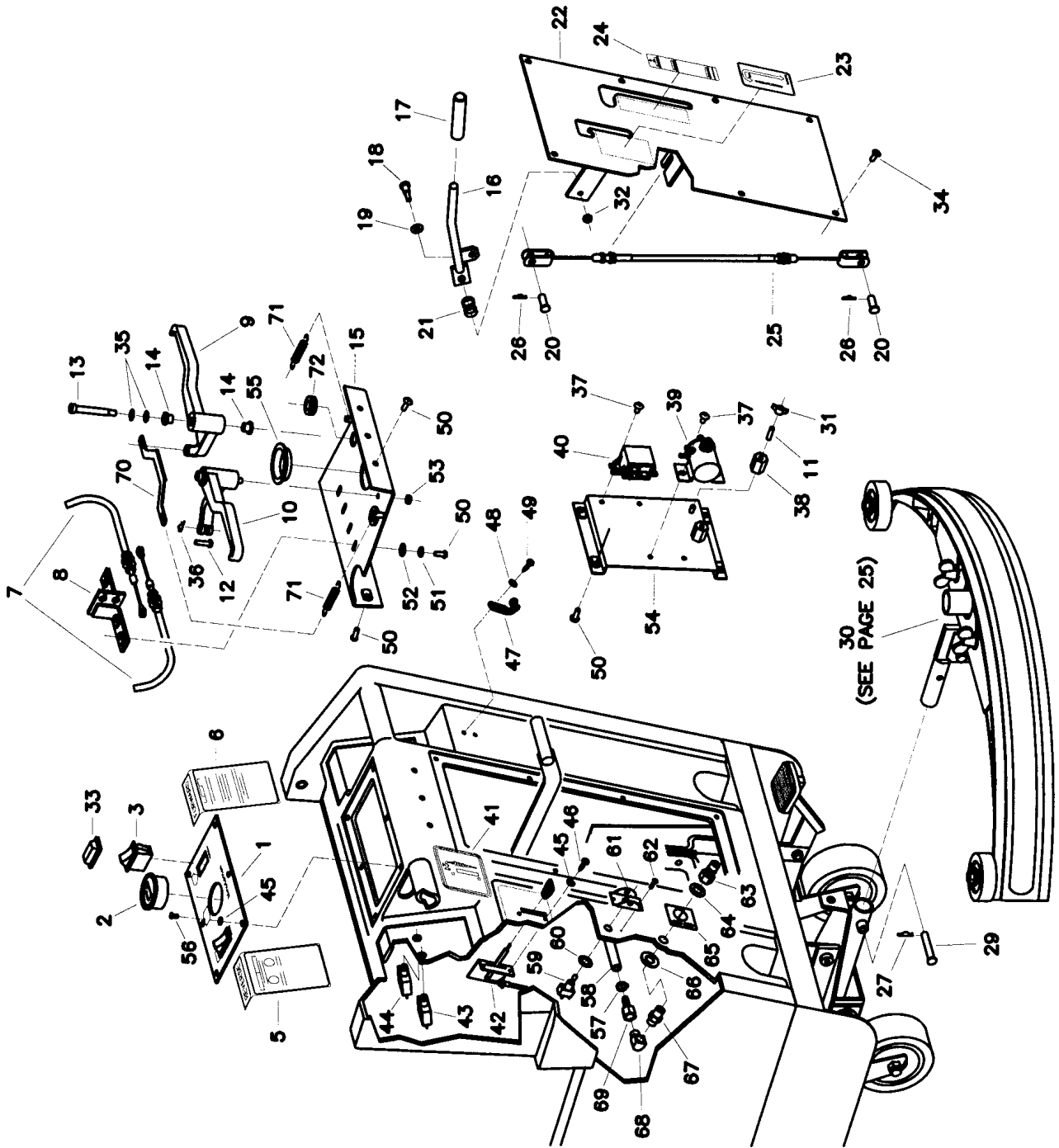

# Brush Driven Parts List

Item	Part No.	Qty.	Description	Item	Part No.	Qty.	Description
1	260084BDSP	1	Dashboard, Screen Printed	36	809311	2	Cotter Pin
1CE	260084BCEDSP	1	Dashboard, CE Screen Printed	37	710178	4	SCR-MC 1/4-20 x .50
2	740216	1	Gauge Battery Condition	38	740132	2	Insulator Glastic
3	809754	2	Switch Rocker	39	788147	1	Solenoid 24V
3CE	740711CE	2	Switch Rocker CE	40	740241	1	Contacto 24V 50 amp
4				41	715604	1	Decal Solution 260
5	715602	1	Decal Reverse 260	42	210045	1	Cable Solution Control
6	715601	1	Decal Forward 260	43	740247	1	30 amp Circuit Breaker
7	260053	2	Cable	44	740131	1	70 amp Circuit Breaker
8	260081	1	Cable Mount	45	712320	8	WSR-Nylon .22 x .45 x .04
9	260070MCH	1	Right Handle	46	711125	2	SCR-ST-B 10 x .50
10	260069MCH	1	Left Handle	47	760286	1	Wire Formed Hook
11	833638	2	Brass Stud	48	711503	2	WSR-Flat 10
12	881002	2	Clevis Pin 5/16 x 1	49	711161	2	SCR-HI/LO 10 x .75
13	712100	2	Bolt-Shoulder 3/8 x 2.25	50	710180	17	SCR-MC 1/4-20 x .75
14	260066	4	3/8 Oilite Flanged Bushing	51	711544	4	WSR-Helical 1/4
15	260099	1	Platform Handle	52	711505	4	WSR-Flat 1/4
16	260286	1	Squeezeee Lift Arm	53	711420	2	Nut-Hex Jam 5/16-18
17	260291	1	Handle Grip	54	260173	1	Electrical Panel
18	712070	1	Bolt-Shoulder 5/16 x .75	55	762400	1	Heyco Bushing
19	711575	1	WSR-Flat .312 x .75	56	712540	6	SCR-MC 10-24 x .37 TH
20	711668	2	Clevis Pin 3/8 x 1.00	57	450076	1	Crimp Clamp SS 185R
21	833102	1	Spring Compression	58	260194	1	Hose Nyobraid C/L 50
22	260284	1	Back Panel	59	740188	1	Toggle Switch
23	715603	1	Decal Squeezeee Lift 260	60	712310	1	WSR-Flat .52 x .87 x .06
24	715605	1	Decal Brush Position 260	61	760277	1	Switch Guard
25	260266	1	Squeezeee Lift Cable Assembly	62	711128	2	SCR-HI/LO 8 x .62
26	833374	2	Cotter Pin	63	828368	1	BH2-61 Male Coupler
27	711808	1	Cotter Pin	64	711594	1	WSR-Flat .56 x .88 x .03
28				65	715144	1	Decal Aux. Pump
29	711671	1	Clevis Pin .306 x 2.125	66	711595	1	WSR-Flat .59 x 1.18 x .09
30	320297	1	Squeezeee Assembly Complete	67	450059	1	1/4 NPT Bulkhead Fitting
31	711368	2	Wing Nut	68	831306	1	Street 90 1/4 Brass
32	711373	1	Nut-Nyloc 1/4-20	69	833473	1	Hose Barb 1/4 FPT x 3/8 Barb
33	802657	2	Switch Boot	70	260325	1	Handle Bracket
34	712822	8	SCR-MC 10-24 x .50 TH	71	430051	2	Retainer Spring
35	711523	4	WSR-WAVE .38 x .68 x .01	72	260274	2	Grommet

# Traction Driven

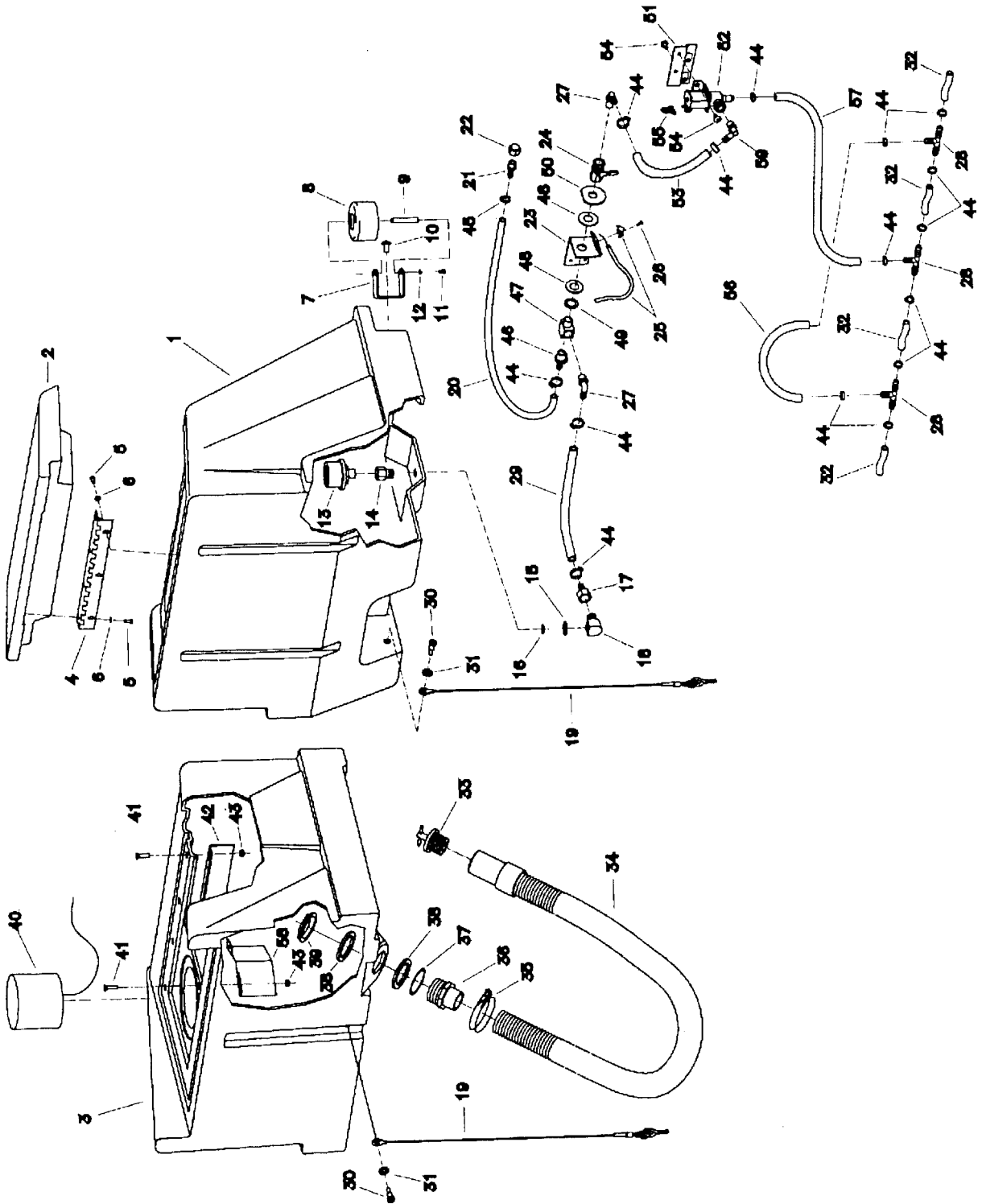

# Traction Driven Parts List

Item	Part No.	Qty.	Description	Item	Part No.	Qty.	Description
1	260092	1	Solution Tank	30	712041	2	Bolt-Shoulder 5/16 x .37
2	260029	1	Solution Lid	31	711506	2	WSR-Flat 5/16
3	260091	1	Recovery Tank	32	260179	4	Hose Nylobraid 2.375"
4	450021	1	Hinge	33	833316	1	Drain Plug 1 1/4
5	712822	7	SCR-THMS 10-24 x .50	34	260202	1	Drain Hose Assembly
6	711503	7	WSR-Flat 10	35	260203	1	Hose Clamp Wire Grip
7	832949	2	Bracket, Bumper	36	760220MCH	1	1.5 Adapter Gray
8	832896	2	Guide Wheel	37	450081	1	WSR-SS 1.908 x 2.41 x .03
9	833254	2	Bumper Wheel Axle	38	828970	2	WSR-Neop 1.81 x 2.37
10	710985	2	SCR-SC 3/8-16 x .62	39	828971	1	Nut 1 1/2 Pipe Thread
11	710353	2	SCR-MC 10-32 x .37	40	260156	1	Foam Float Assembly
12	711553	2	WSR-Internal Lock 10	41	712563	6	SCR-MCH 1/4-20 x 1.00 F.H.
13	130118	1	Solution Strainer M3-40	42	260184	1	Backing Angle
14	210409	1	Adapter Brass 3/8 FPT x 3/8 MPT	43	712667	6	Nut-SS Nyloc 1/4-20
15	711513	1	WSR-Flat .69 x 1.06 x .03 SS	44	450076	15	Crimp Clamp SS 185R
16	210414	1	O-Ring	45	828490	2	Hose Clamp
17	210410	1	3/8 Hose Barb x 3/8 FPT Brass	46	342430	1	Hose Barb 3/8 MPT x 3/8 BARB
18	830062	1	90° Street Elbow 3/8 x 3/8	47	210408	1	3/8 Brass Tee
19	260214	2	Tank Cable Assembly	48	828975	1	WSR-Neoprene .75 x 1.5 x .09
20	260162	1	Hose - Clear 3/8 ID	49	711512	1	WSR-Flat .75 x 1.37 x .08
20A	260193	1	Hose - Nylobraid C/L 14.50	50	829463	1	WSR-Flat D .75 x 2.00 x .05
21	828952	1	PLS 3/8 Barb x 1/4 MPT	51	260215	1	Solenoid Bracket
22	430114	1	Nylon Cap 1/4 FPT	52	740493	1	Water Valve
23	210370	1	Solution Valve Cable Mount	53	320254	1	Hose Wire Reinforced 9"
24	809413MCH	1	Valve, Solution	54	712560	4	SCR-MCH 1/4-20 x .50 SS NYL
25	210045	1	Solution Control Cable	55	740482	1	Diode Assembly
26	711124	1	SCR-ST-B 10 x .37	56	450055	1	Hose Nylon Reinforced 9"
27	450040	4	90° 3/8 Barb x 3/8 MPT	57	260216	1	Hose Wire Reinforced 14.75"
28	260178	3	3/8 Barb Tee	58	260303	1	Deflector
29	260182	1	Hose Wire Reinforced 18"	59	833325	1	90° 3/8 Barb x 1/4 MPT

# Traction Driven

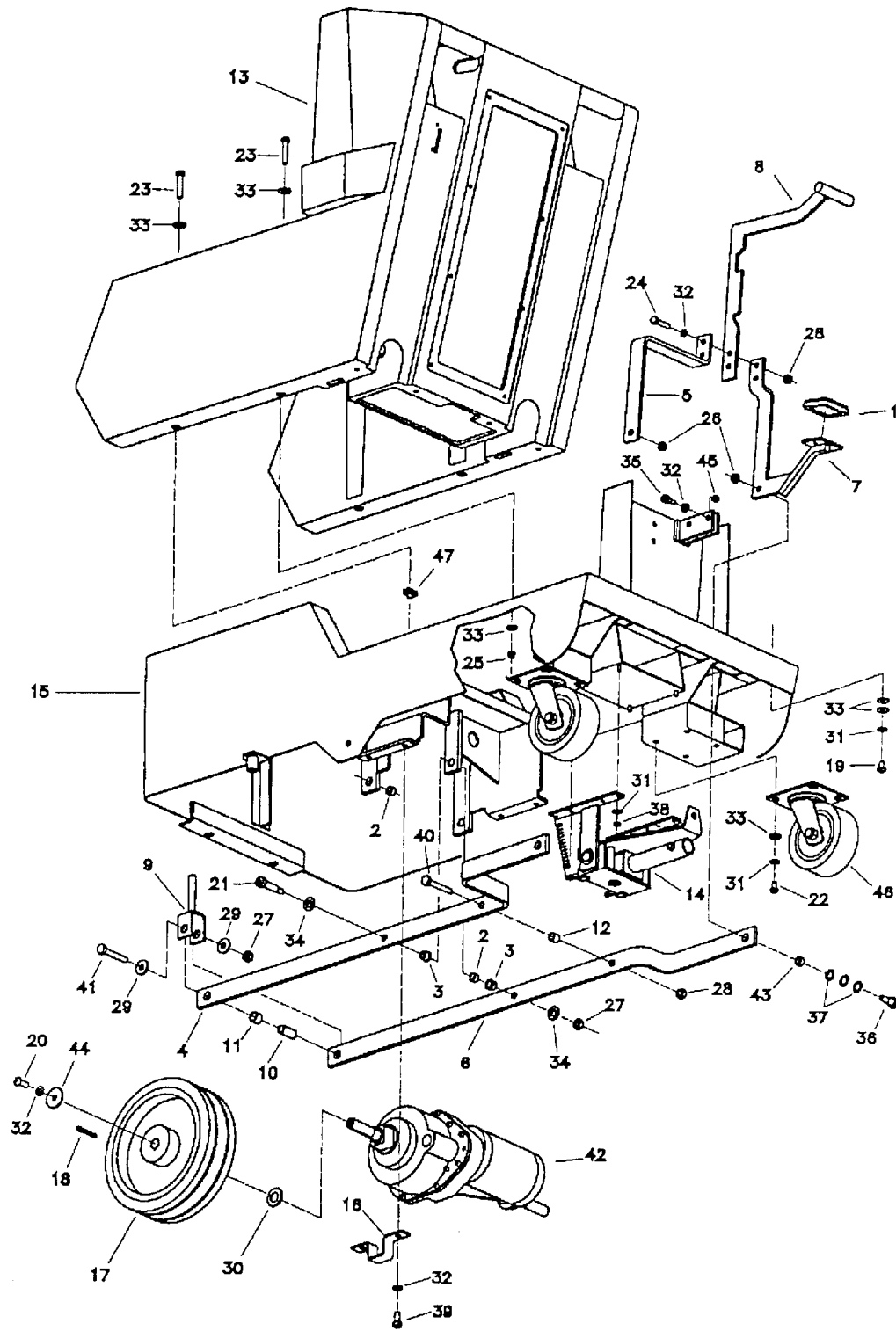

# Parts List

## Traction Driven

Item	Part No.	Qty.	Description
1	210142	1	Pedal Pad
2	260030	5	½ Oilite Bushing
3	260041	2	Oilite Flange Bushing
4	260043	1	Lift Arm, Left Side
5	260046	1	Pedal Brace
6	260044	1	Lift Arm, Right Side
7	260054	1	Pedal Weldment
8	260055	1	Lift Handle Weldment
9	260075	1	Yoke Weldment
10	260125	1	Bushing, Yoke
11	260128	1	Spacer
12	260141	1	Spacer
13	260256	1	Base Assy. Machined
14	260317	1	Squeegee Mech. Assy. Comp.
15	260360	1	Mainframe Weldment
16	260366	2	Transaxle Bracket
17	260370	2	Wheel 10" x 2.75 x .75
18	260371	2	Key 3/16 x 3/16 x 2.00
19	710196	4	SCR-MC 5/16-18 x .75
20	710986	2	SCR BHCS 3/8-16 x 1.00
21	710992	1	Shoulder Bolt ½ x 1.25
22	711228	8	Bolt-HH 5/16-18 x .75
23	711232	4	Bolt-HH 5/16-18 x 1.50
24	711250	2	Bolt-HH 3/8-16 x 1.25
25	711374	2	Nut Nyloc 5/16-18
26	711375	2	Nut-Nyloc 3/8-16 Low
27	711380	2	Nut, Nyloc 3/8-16
28	711439	3	Nut-Flanged Wizz 3/8-16
29	711507	2	WSR-Flat .37 x 1.12 x .06
30	711512	2	WSR-Flat .75 x 1.37 x .08
31	711545	16	Washer Helical 5/16
32	711546	10	Washer Helical 3/8
33	711575	22	Washer Flat 5/16
34	711579	2	WSR-Flat ½ x 1.00
35	712081	2	Shoulder Bolt 3/8 x .75
36	712099	2	Shoulder Bolt ½ x .50
37	712310	6	WSR-Flat .52 x .87 x .06
38	712680	4	Nut-Hex 5/16-18 SS
39	713042	4	Bolt-HH 3/8-16 x 1.00 #5
40	713045	1	Bolt-HH 3/8-16 x 1.75 #5
41	713048	1	Bolt-HH 3/8-16 x 2.50
42	744160	1	Transaxle 13" 24V
43	762340	2	Oilite Bushing
44	809226	2	WSR-Flat .40 x 1.50 x .12
45	809247	2	Spacer .38 x .50 x .32
46	827110	2	Caster 5"
47	832829	2	Nut-Tinnerman 5/16-18

# Traction Driven

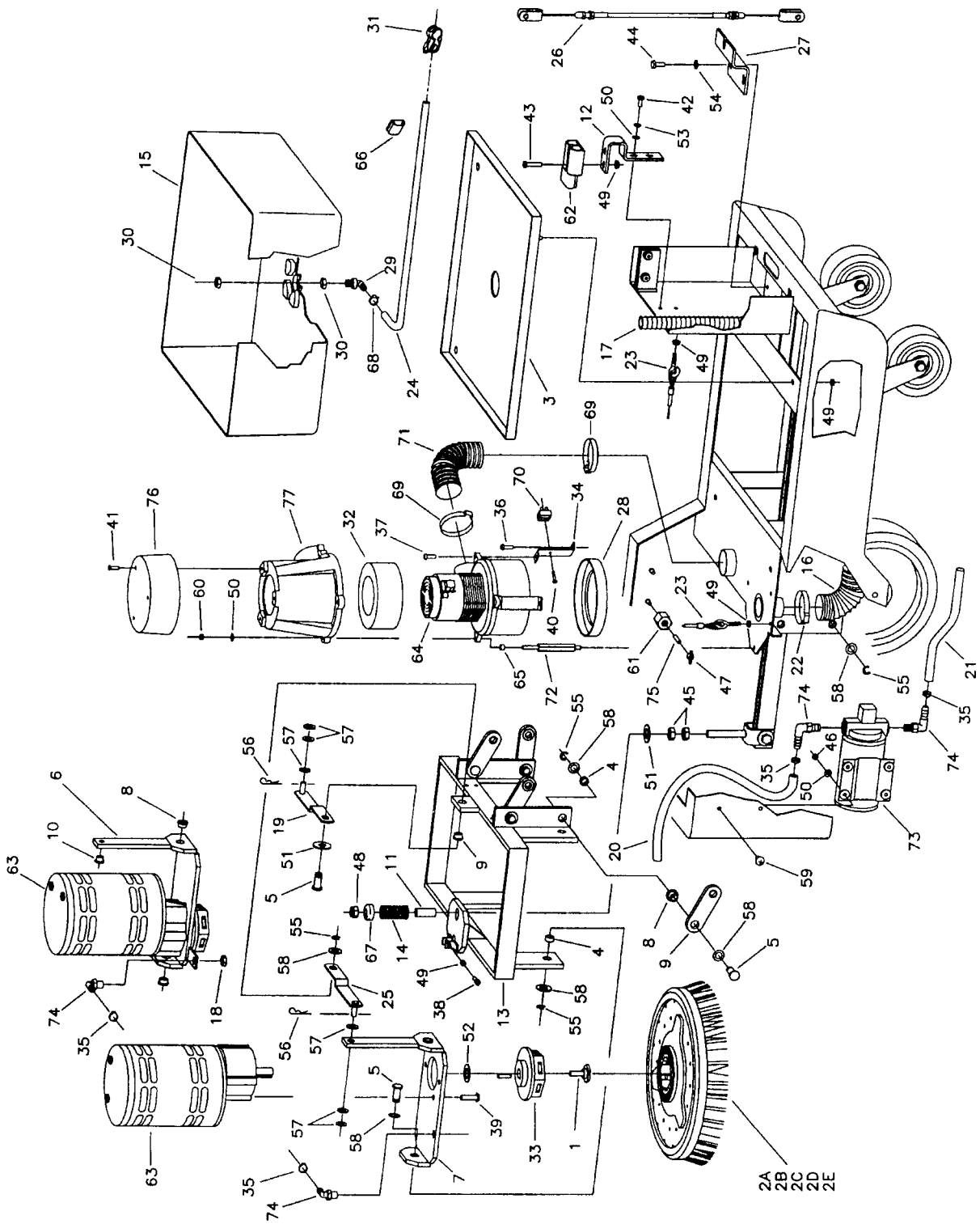

# Traction Driven Parts List

Item	Part No.	Qty.	Description	Item	Part No.	Qty.	Description
1	210066	2	Drive Hub Retainer Bolt	38	710823	2	SCR-SC 1/4-20 x .50 Nylon
2A	260002	2	Pad Driver	39	710986	8	SCR-SC 3/8-16 x 1.00
2B	260003	2	Bassine Brush	40	711128	1	SCR-TF 8 x .62
2C	260004	2	Nylon Brush	41	711160	3	SCR HI/LO 10 x .62
2D	260005	2	Polygrip Brush	42	711203	2	Bolt-HH 1/4-20 x .62
2E	260006	2	Stratagrit Brush	43	711210	2	Bolt-HH 1/4-20 x 1.25
3	260009	1	Battery Tray	44	711228	2	Bolt-HH 5/16-18 x .75
4	260030	8	1/2 Oiliite Bushing	45	711334	2	Nut-Hex 1/2-13
5	260036	13	Pin	46	711350	4	Nut-Hex Nyloc 10-32
6	260038	1	Motor Mount, R.H.	47	711368	2	Wing Nut
7	260039	1	Motor Mount, L.H.	48	711376	2	Nut-Nyloc 1/2-13
8	260041	13	1/2 Oiliite Flange Bushing	49	711425	10	Nut-Flanged Wizz 1/4-20
9	260049	4	Linkage Bar	50	711505	7	WSR-Flat 1/4
10	260066	2	3/8 Oiliite Flange Bushing	51	711510	2	WSR-Flat .50 x 1.37 x .10
11	260068	1	Sleeve, Spring	52	711517	2	WSR-Flat .77 x 1.37 x .03
12	260076	1	Bracket Anderson Plug	53	711544	2	WSR-Helical 1/4
13	260077	1	Motor Frame	54	711545	2	WSR-Helical 5/16
14	260137	1	Compression Spring	55	711713	13	1/2 Retaining Ring
15	260150	1	Battery Liner	56	711808	2	Cotter Pin
16	260159	1	Vac Hose Clr. 1.5 x 78	57	712301	6	WSR-Flat .37 x .87 x .06
17	260175	1	Conduit	58	712310	25	WSR-Flat .52 x .87 x .06
18	260183	2	Nut-PLS 1/4 NPT	59	712545	4	SCR-MC 10-32 x .87 SS
19	260187	1	Retainer Bar, R.H.	60	712667	1	Nut-Nyloc 1/4-20
20	260193	1	Hose Nylobraid C/L 14.50	61	740132	2	Glastic Insulator
21	260194	1	Hose Nylobraid C/L 50	62	740159	1	SB175 Red Quick Disconnect
22	260203	1	Wire Grip Hose Clamp	63	740209	2	Gearmotor 24V
23	260214	2	Tank Cable Assy.	64	740225	1	Vac Motor 24V 3-Stage
24	260224	1	Hose Clr. 18"	65	762073	1	Spacer
25	260250	1	Retainer Bar, L.H.	66	809444	1	Clip Cord
26	260266	1	Squeegee Lift Cable Assy.	67	828264	1	Washer Cup
27	260315	1	Lift Cable Bracket	68	828490	1	Hose Clamp
28	290017	1	Molded Gasket	69	829067	2	Hose Clamp
29	320271	1	90° Nozzle	70	832996	1	Terminal Block
30	320272	2	Nozzle Lock Nut	71	833191	1	Hose Rubber Flex 2 x 9
31	320273	1	Hose Shut-Off Clamp	72	833265PLT	1	Standoff 1/4-20
32	380064	1	Foam Ring	73	833299	1	Pump 100 PSI 24V DC (optional)
33	430035	2	Drive Hub	74	833325	4	90° 3/8 Barb x 1/4 MPT
34	450038-H	2	Z-Bracket VDE	75	833638	2	Brass Stud
35	450076	4	Crimp Clamp SS 185R	76	840011	1	Vac Motor Cover, Top
36	710180	2	SCR-MC 1/4-20 x .75	77	840012	1	Vac Motor Cover, Bottom
37	710129	2	SCR-TR 1/4-20 x 1.00 HWH	78			



# Traction Driven

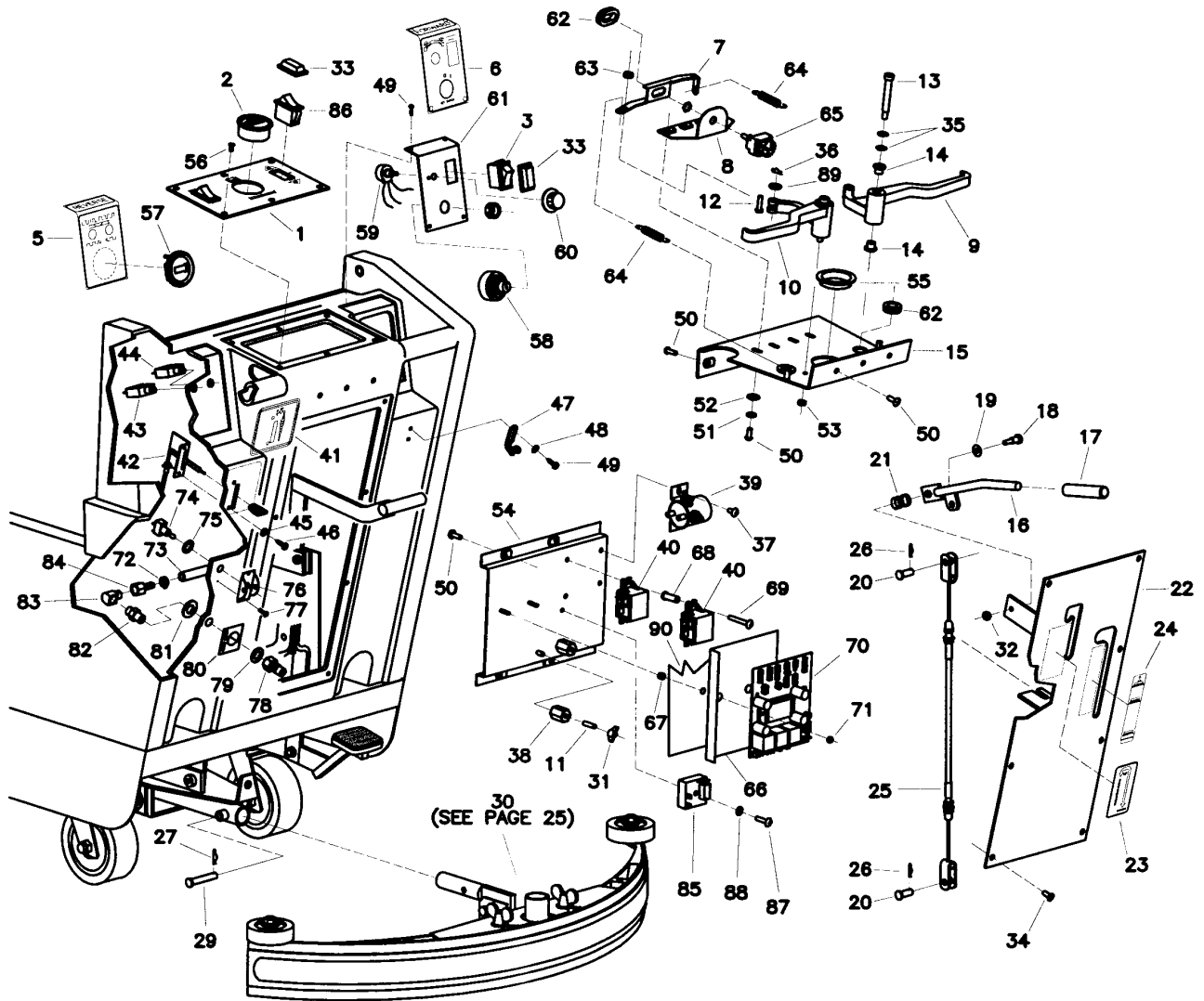

# Parts List

Item	Part No.	Qty.	Description	Item	Part No.	Qty.	Description
1	260084TDSP	1	Dashboard Screen Printed	46	711125	2	SCR-ST-B 10 x .50
1CE	260084CETDSP	1	Dashboard CE Screen Printed	47	760286	1	Wire Formed Hook
2	740216	1	Gauge Battery Condition	48	711503	2	WSR-Flat 10
3	809754	2	Switch Rocker	49	711161	6	SCR-HI/LO 10 x .75
3CE	740711CE	2	Switch Rocker CE	50	710180	15	SCR-MC 1/4-20 x .75
4				51	711544	4	WSR-Helical 1/4
5	715602	1	Decal Reverse 260	52	711505	4	WSR-Flat 1/4
6	715608	1	Decal Forward 260TD	53	711420	2	Nut-Hex Jam 5/16-18
7	260254	1	Switch Actuator	54	260253	1	Electrical Panel 260TD
8	260198	1	Switch Mounting Bracket	55	762400	1	Heyco Bushing
9	260070MCH	1	Right Handle	56	712540	6	SCR-MC 10-24 x .37 TH
10	260069MCH	1	Left Handle	57	741007	1	Hour Meter (optional)
11	833638	2	Brass Stud	58	741005	1	Keyswitch (optional)
12	881002	2	Clevis Pin 5/16 x 1	59	740804	1	Potentiometer Assembly
13	712100	2	Bolt-Shoulder 3/8 x 2.25	60	809874	1	Knob
14	260066	4	3/8 Oilite Flanged Bushing	61	260255	1	Speed Control Bracket
15	260099	1	Platform Handle	61CE	260255CE	1	Speed Control Bracket CE
16	260286	1	Squeegee Lift Arm	62	260274	3	Rubber Grommet
17	260291	1	Handle Grip	63	832015	2	Spacer
18	712070	1	Bolt-Shoulder 5/16 x .75	64	430051	2	Return Spring
19	711575	1	WSR-Flat .312 x .75	65	827060	1	Forward/Reverse Switch
20	711668	2	Clevis Pin 3/8 x 1.00	66	805637	1	Fiber Insulator
21	833102	1	Spring Compression	67	200340	2	Spacer
22	260284	1	Back Panel	68	828935	2	Spacer
23	715603	1	Decal Squeegee Lift 260	69	712570	2	SCR-MC 1/4-20 x 1.75 SS
24	715605	1	Decal Brush Position 260	70	740944	1	SCR Control Board 24V
25	260266	1	Squeegee Lift Cable Assembly	71	711372	2	Nut-Nyloc 8-32
26	833374	2	Cotter Pin	72	450076	1	Crimp Clamp SS 185R
27	711808	1	Cotter Pin	73	260194	1	Hose Nylobraid C/L 50
28				74	740188	1	Toggle Switch
29	711671	1	Clevis Pin .306 x 2.125	75	712310	5	WSR-Flat .52 x .87 x .06
30	320297	1	Squeegee Assembly Complete	76	760277	1	Switch Guard
31	711368	2	Wing Nut	77	711128	2	SCR-HI/LO 8 x .62
32	711373	1	Nut-Nyloc 1/4-20	78	828368	1	BH2-61 Male Coupler
33	802657	3	Switch Boot	79	711594	1	WSR-Flat .56 x .88 x .03
33CE	740811CE	3	Switch Boot CE	80	715144	1	Decal Aux. Pump
34	712822	8	SCR-MC 10-24 x .50 TH	81	711595	1	WSR-Flat .59 x 1.18 x .09
35	711523	4	WSR-WAVE .38 x .68 x .01	82	450059	1	1/4 NPT Bulkhead Fitting
36	809311	2	Cotter Pin	83	831306	1	Street 90 1/4 Brass
37	710178	4	SCR-MC 1/4-20 x .50	84	833473	1	Hose Barb 1/4 FPT x 3/8 Barb
38	740132	2	Insulator Glastic	85	741037	1	5 Second Time Delay
39	788147	1	Solenoid 24V	86	740736	1	Vacuum Switch
40	740241	2	Contact 24V 50 amp	86CE	742102	1	Vacuum Switch CE
41	715604	1	Decal Solution 260	87	712814	1	SCR-MC 10-24 x .87 STPL
42	210045	1	Cable Solution Control	88	711553	1	WSR-Internal Lock No. 10
43	740247	1	30 amp Circuit Breaker	89	711506	2	WSR-Flat 5/16
44	740131	1	70 amp Circuit Breaker	90	260210	1	Clear Polyethylene Sheet
45	712320	2	WSR-Nylon .22 x .45 x .04				

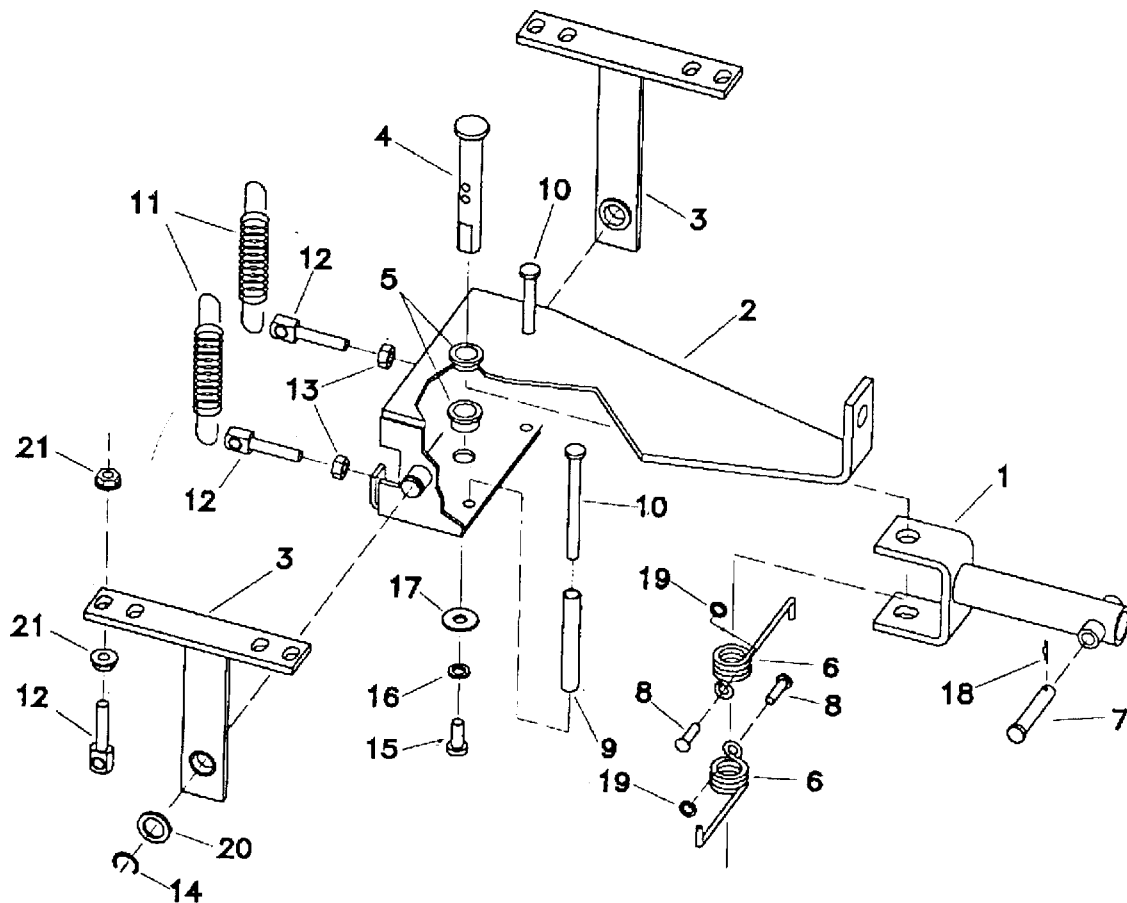

**260317**  
**Squeegee Mechanism**  
**Assembly**

Item	Part No.	Qty.	Description
1	260312	1	Yoke Weldment
2	260314	1	Spring Housing Weldment
3	320008	2	Pivot Bracket Weldment
4	210375	1	Swivel Pin
5	260041	2	1/2 Oilite Bushing
6	210391	2	Torsion Spring SS
7	711671	1	Clevis Pin 5/16 x 2.125
8	712536	2	SCR-MC 10-24 x .62
9	210400	2	Spacer Tube
10	712592	2	SCR-MC 1/4-20 x 2.75
11	430051	2	Return Spring
12	260292	4	Swing Bolt
13	712665	2	Nut-Hex 1/4-20
14	711715	2	3/4 Retaining Ring
15	712562	1	Bolt-HH 1/4-20 x .75 SS
16	712758	1	WSR-Helical 1/4 SS
17	711504	1	WSR-Flat .25 I.D. SS
18	711808	1	Cotter Pin
19	712320	2	WSR-Nylon .22 x .45 x .04
20	711517	2	WSR-Flat .75 x 1.375 x .09 SS
21	711425	2	Nut-Flange Wizz 1/4-20

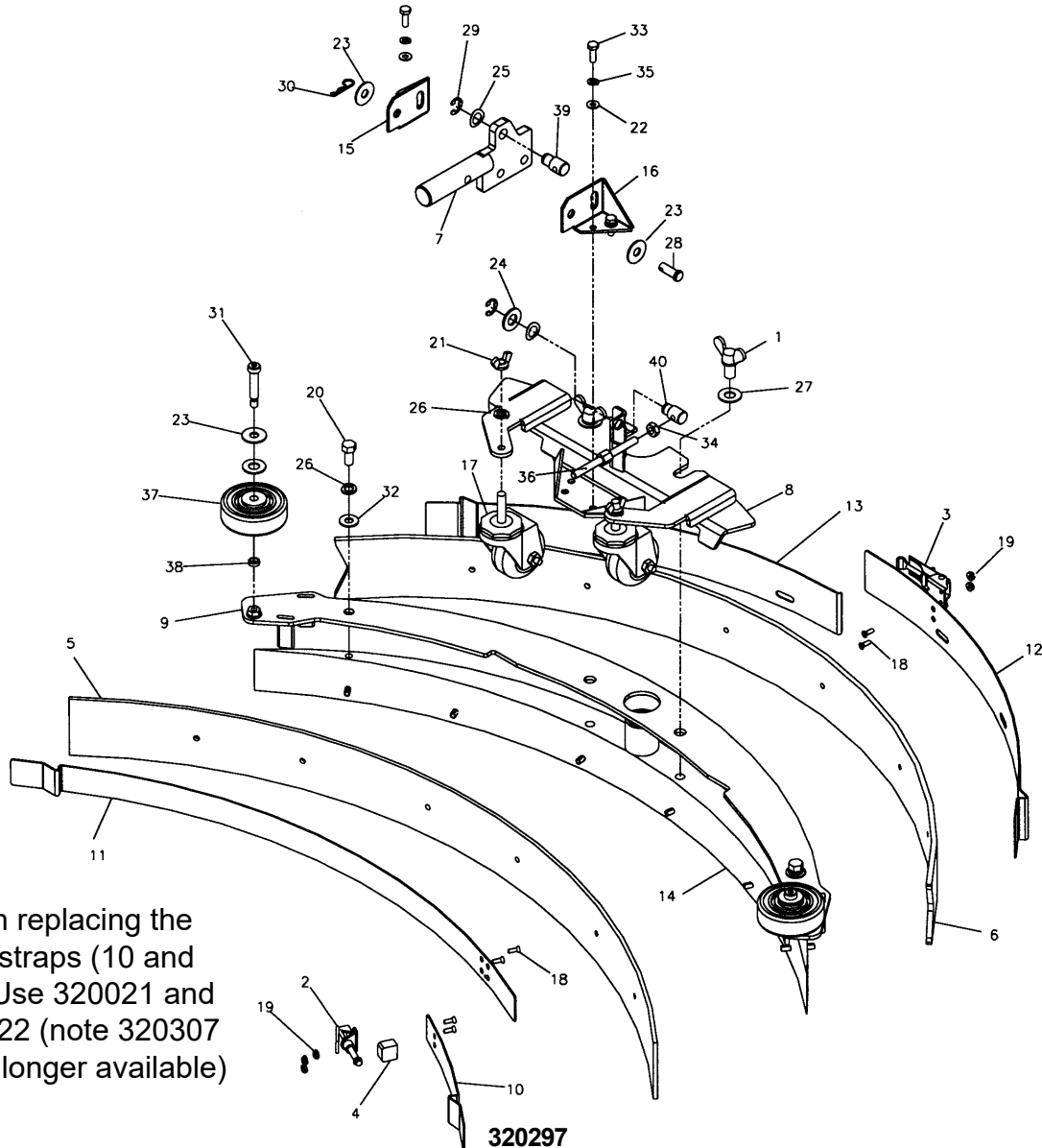

**SQUEEGEE ASSEMBLY COMPLETE**

Item	Part No.	Qty.	Description	Item	Part No.	Qty.	Description
1	220249	2	Wing Bolt 1/2-13 x .75"	21	711367	2	Nut-Wing 3/8-16 ST PL
2	281074	1	Squeegee Toggle Clamp, 2800	22	711504	4	WSR-Flat 1/4 ID SS
3	281075	1	Squeegee Latch, 2800	23	711507	4	WSR-Flat .37 x 1.12 x .06
4	281740	1	Stop Bar	24	711509	1	WSR-Flat 1/2 (.54 x 1.08 x .087)
5	320014	1	Squeegee Front Blade 320	25	711524	2	WSR-Wave .52 x .87 x .01
6	320015	1	Squeegee Rear Blade 320	26	711546	4	WSR-Helical 3/8
7	320154	1	Squeegee Mount Weld't New	27	711592	4	WSR-Nylon .50 x 1.06 x .06
8	320289	1	Sq Mtg Brkt Weldm't	28	711668	1	Cleavis Pin, 3/8 x 1 11-141
9	320293	1	Top Plate Weldment, 320	29	711713	2	Retaining Ring - "E" Type Ext .500
10	320307	1	Strap-Front Stop 320	30	711808	1	Cotter Pin - Hair #13
11	320308	1	Strap-Front Clamp 320	31	712091	2	Bolt-Shoulder 3/8 x 1.50
12	320310	1	Strap-Rear Latch 320	32	712301	2	WSR-Flat .87 x .37 x .06
13	320313	1	Strap-Catch 320	33	712562	4	Bolt-HH 1/4-20 x 3/4 SS
14	320314	1	320 Sq Casting Mchd, New	34	712680	1	Nut-Hex 5/16-18 SS
15	383424	1	Mounting Bracket-Right	35	712758	4	WSR-Helical 1/4 SS
16	383425	1	Mounting Bracket-Left	36	750689	1	Adjustment Stud
17	430325	2	Caster Wheel 3/8"-16 x 1.500	37	808829	2	Wheel, Truck
18	710530	7	SCR-MC 8-32 x .50 BR	38	832015	2	Spacer .38 x .50 x .140
19	711026	5	Nut, Hex 8-32 Nyloc SS	39	762022PLT	1	Nut, Adjusting (LH)
20	711241	2	SCR-Hex 3/8-16 x .75" ZP	40	762257PLT	1	Nut, Adjusting (RH)











# LIMITED WARRANTY

Minuteman International, Inc. warrants to the original purchaser/user that this product is free from defects in workmanship and materials under normal use and service for a period of three years from date of purchase. In addition, Minuteman International, Inc. will, at its option, honor labor warranty claims for the first 12 months from date of sale, provided such claims are submitted through and approved by factory authorized repair stations. Minuteman International, Inc. will, at its option, repair or replace without charge, except for transportation costs, parts that fail under normal use and service when operated and maintained in accordance with the applicable operation and instruction manuals.

This warranty does not apply to normal wear, or to items whose life is dependent on their use and care, such as belts, cords, switches, hoses, rubber parts, electrical motor components or adjustments. Parts not manufactured by Minuteman International, Inc. such as engines, batteries, battery chargers, hydraulic pumps, and tires are covered by and subject to the warranties and/or guarantees of their manufacturers. Please contact Minuteman International, Inc. for procedures in warranty claims against these manufacturers.

**Special warning to purchaser** — Use of replacement filters and/or prefilters not manufactured by Minuteman International, Inc. or its designated licensees, will void all warranties expressed or implied.

A potential health hazard exists without exact original equipment replacement.

All warranted items become the sole property of Minuteman International, Inc. or its original manufacturer, whichever the case may be.

Minuteman International, Inc. disclaims any implied warranty, including the warranty of merchantability and the warranty of fitness for a particular purpose. Minuteman International, Inc. assumes no responsibility for any special, incidental or consequential damages.

This limited warranty is applicable only in the U.S.A. and Canada, and is extended only to the original user/purchaser of this product. Customers outside the U.S.A. and Canada should contact their local distributor for export warranty policies. Minuteman International, Inc. is not responsible for costs or repairs performed by persons other than those specifically authorized by Minuteman International, Inc. This warranty does not apply to damage from transportation, alterations by unauthorized persons, misuse or abuse of the equipment, use of non-compatible chemicals, or damage to property, or loss of income due to malfunctions of the product.

If a difficulty develops with this machine, you should contact the dealer from whom it was purchased.

This warranty gives you specific legal rights, and you may have other rights which vary from state to state. Some states do not allow the exclusion or limitation of special, incidental or consequential damages, or limitations on how long an implied warranty lasts, so the above exclusions and limitations may not apply to you.

## ***Minuteman***<sup>®</sup>

**World Headquarters**  
Minuteman International, Inc.  
111 South Rohlwing Road  
Addison, Illinois 60101

Minuteman Canada, Inc.  
2210 Drew Road  
Mississauga, Ontario  
L5S 1B1

(630) 627-6900  
FAX (630) 627-1130

(905) 673-3222  
FAX (905) 673-5161

988010  
Printed in U.S.A.